

Dead Weight Testers

Pressure Ranges .25 to 60 bar and .25 to 100 bar

Models **PD 60**
PD 100

Dead weight testers are used for checking and calibrating pressure gauges and other pressure measuring instruments. The main components are the measuring system, the valve unit, the built-in screw pump for accurate pressure adjustment, and the weights.

The measuring system itself consists of a precise lapped-in pair of piston and cylinder. During the measuring process the piston is forced up by the pressure created with the built-in screw pump and eventually with additional external pressure supply, while the regular weights and maybe further extra weights, if required for the desired test pressure, press it down.

With the built-in screw pump the test pressure can be adjusted to an equilibrium of the forces. When the forces acting on both sides of the piston are in balance, the piston will be floating, and the desired test pressure is reached exactly.

For simplifying the handling, the weights are already referred to each relevant determined piston area and stamped with the pressure unit (bar/MPa).

The friction between piston and cylinder is minimized by keeping piston and weights rotating while floating.

The models described in this data sheet are available for pressure ranges .25 to 60 bar (PD 60) resp. .25 to 100 bar (PD100).

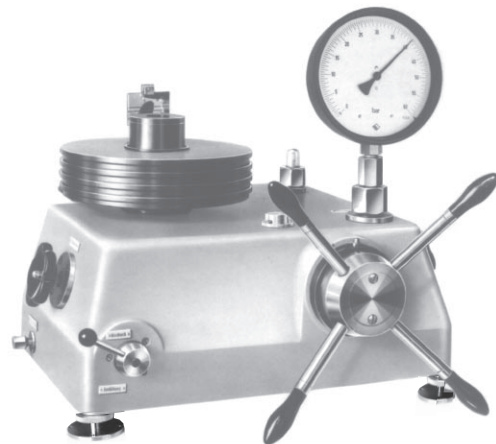

Technical Data

Pressure Ranges

.25 to 60 bar (PD 60)

.25 to 100 bar (PD 100)

Set of Weights

in bar / MPa

External Admission Pressure

Compressed air up to 10 bar, recommended for a faster filling of the system

Accuracy

Better than .05% (with or without certificate B according to EN 10204) respectively .03% (only with certificate from German gauging office or DKD¹⁾);

Max. error up to 6 bar = constantly

±3 mbar (for accuracy .05% f.s.) respectively

±1.8 mbar (for accuracy .03% f.s.)

Reference Conditions

Ambient temperature + 20 °C ± 2 °C

Fall acceleration = 9,8102 m/s²

Dimension of Cross Section of the Piston

.5 cm² ± 0,2 %

Piston Drive

Electrical motor (220 VAC/50 Hz/45 mA)

Instrument Connections

2 union nuts, one of each ½" BSP and M 20x1.5

Connection for External Admission Pressure

Prestolock plug connection for PA tubing N 4x1 and adapter for N 6x1 tubing

Medium

Special oil

Case

Grey cast aluminum 490 x 480 x 330 mm (L x B x H) PD 60
(19.29" x 18.9" x 12.99"),

490 x 480 x 400 mm (L x B x H) PD 100
(19.29" x 18.9" x 15.48")

(dimensions including the star handle),

with 3 feet, adjustable for accurate horizontal positioning according to the integrated leveling bubble

Required Working Surface

520 x 450 mm (20.47" x 17.72")

Weights (approx.)

	PD 60	PD 100
● Dead weight tester	27 kg (59.5 lb)	28 kg (61.7 lb)
● Sets of weights	36 kg (79.4 lb)	57 kg (125.7 lb)
● Transport box	21 kg (46.3 lb)	21 kg (46.3 lb)
● Transport boxes for sets of weights	4 kg (8.8 lb)	2x4 kg (2x8.8 lb)

PD 60: 1 box; PD 100: 2 boxes

Inclosure to Shipment

- 1 User Instructions (DS 10915)
- 1l Special oil (as pressure medium)
- 1 Cover cap
- 1 Union nut M 20 x 1.5
- 1 Union nut ½" BSP (mounted to the instrument)
- 1 Special gasket, encasing 2 O-rings, for sealing the instrument connection (already installed)
- 4 O-rings as spare parts
- 2 Adapters N 6x1 flexible tubing (for external admission pressure)
- 1 Blind plug for oil drain port (21)

Special Options

- Sets of weights in kp/cm², others upon request
- Certificate B according to EN 10 204
- Certificate from German gauging office or DKD¹⁾ (therefore the exact site for the instrument has to be stated when ordering)
- Connection adapter N 4x1 tubing to ¼" NPT male
- PA tubing N 4x1 for Prestolock connection

How to Order

Model Code: **PD 60** (= .25 to 60 bar) or
PD 100 (= .25 to 100 bar)

Special Configuration (see above)

¹⁾DKD = Deutscher Kalibrierdienst (German Calibration Service)



ARMATURENBAU GmbH

Manometerstraße 5 • D-46487 Wesel - Ginderich
Phone: (0 28 03) 91 30-0 • Fax: (0 28 03) 10 35
armaturenbau.com • mail@armaturenbau.com



Subsidiary Company and Sales East Germany and Eastern Europe

MANOTHERM Beierfeld GmbH

Am Gewerbepark 9 • D-08340 Beierfeld
Phone: (0 37 74) 58 - 0 • Fax: (0 37 74) 58 - 545
manotherm.com • mail@manotherm.com

10915
12/02

User Instructions

⚠ ATTENTION!

Do not carry the instrument by holding on to any other part except to the case itself, especially NOT by holding on to the measuring system! This could lead to serious damages!

The instrument is supplied with a filled oil reservoir (3). Therefore the instrument may not be tilted. Anyway, if the oil should have leaked out, the reservoir has to be refilled as described below.

STARTING OPERATION

The dead weight tester and the sets of weights are supplied in separate wooden transport boxes.

- Release the transport screws before taking the instrument out of the transport box.
- Set up the instrument on the operation place and adjust the position according to the integrated leveling bubble by screwing the feet inside respectively outside of the case until the perfect horizontal level is reached.
- The feet are provided with holes that can be used for fixing the instrument to the table by using appropriate screws.
- Screw the handles into the star handle head of the screw pump.
- Insert the blind plug into the oil drain port (21).
- Plug in the connection for the electrical power (220 VAC) for the motor.

External Admission Pressure

External admission pressure (up to max. 10 bar resp. 150 psi) is recommended for a faster filling of the system.

- For connecting the external admission pressure (compressed air) use a PA tubing N 4x1 that has to be connected to the Prestolock plug connection (7). By applying the adapter that you will find included to the shipment to the Prestolock plug connection (7) a PA tubing N 6x1 can be used instead.
- An air control unit consisting of pressure regulator and filter (pores Ø 10-20 µm, with oil and water separator) has to be placed into the connecting tube between admission pressure and the dead weight tester for contamination protection of the dead weight tester (The filter is not part of standard supply!). The pressure regulator has to be limited to 10 bar (150 psi).

Refilling of the Oil Reservoir (3)

The instrument is supplied with a filled oil reservoir ready for use. Oil must be refilled immediately when the red float stick is no longer visible through the window of the oil column.

Use exclusively the special oil included to shipment respectively re-ordered oil, which we will deliver upon request!

- For refilling the reservoir the change-over valve (18) has to be switched to "Entlüften" (vent).
- Close the admission pressure valve "Vordruck" (9).
- Close the change-over valve (18) by turning the lever to the tag "Zu".
- Remove the union nut and the acrylic cap from the reservoir and fill in the oil up to the rim while pressing down the float.
- Close the reservoir.
- Open the admission pressure valve "Vordruck" (9) und switch the change-over valve (18) to "Entlüften" (vent).

Notice

After approximately 40 operating hours pull the plug out of the drain port (21) and let the oil overflow run out. (Use an appropriate vessel to collect the oil!)

TESTING PRESSURE GAUGES (Using Admission Pressure)

With external admission pressure (up to max. 10 bar resp. 150 psi) the system can be filled faster.

- Starting position: all valves are closed.
- Before connecting the pressure gauge open valve "Prüfanschluss" (11).
- With the screw pump fill in oil up to the sealing face of the connection (13).
- Screw the pressure gauge tight into the connection (Don't hold on the the case of the pressure gauge! Use a suitable wrench on the wrench flat!).
- Open the valves "Vordruck" (9) and "Messsystem" (10).

- Put the weights corresponding to the desired pressure to the base plate (14 resp. 14a). Therefore consider the notice referring the set of weights (following).
- Switch the change-over valve (18) to "Vordruck" (admission pressure) for filling the system.
- That following close valve "Vordruck" (9).
- Use the screw pump (2) to raise the pressure until the piston starts floating.

⚠ ATTENTION!

During measuring operation the piston has to be floating. It may not stay adjacent to the upper or the lower stopper!



In any case the motor has to be switched off and the measuring system has to be stopped before putting on the 10 bar weights! The same goes for pressure relief. Stop the motor before pressure relief!

- Switch on the electrical drive (22).
- By turning the star handle adjust the pressure until the upper edge of the base plate (14) is exactly covering the lower marking line on the mirror (Fig. 3b) respectively until the marking on the ring weight base plate (14a) is same level with the upper marking line of the mirror (Fig. 3a).
- For pressure relief open valve "Vordruck" (9).
- For pressure relief down to "0 bar" the admission pressure has to be relieved, too. Therefore switch the change-over valve (18) to "Entlüften" (vent).



Remove the pressure gauge only after complete pressure relief down to 0 bar!

Notice

Please always pay attention to a clear locking-in of the lever of the change-over valve (18) at the exact position right above the tags.

SET OF WEIGHTS

⚠ ATTENTION!

Treat the set of weights carefully! Avoid all kind of damages!

The set of weights is delivered in 1 wooden box for model PD 60 and in 2 wooden boxes for model PD 100.

PD 60

5 Ring weight plate	10 bar
1 Ring weight plate	for completing the weights of the base plate (14) plus of the ring weight base plate (14a) to 10 bar pressure
4 Disc weight plate	2 bar
1 Disc weight plate	1 bar
2 Disc weight plate	.4 bar
1 Disc weight plate	.2 bar
1 Disc weight plate	.15 bar for completing the weight of the base plate (14) to .4 bar pressure

PD 100

9 Ring weight plate	10 bar
1 Ring weight plate	for completing the weights of the base plate (14) plus of the ring weight base plate (14a) to 10 bar pressure
4 Disc weight plate	2 bar
1 Disc weight plate	1 bar
2 Disc weight plate	.4 bar
1 Disc weight plate	.2 bar
1 Disc weight plate	.15 bar for completing the weight of the base plate (14) to .4 bar pressure

The weights (disc weight plates and ring weight plates) and the base plate (14) are marked with their pressure value in bar and MPa, with the serial number and the total pressure value (60 resp. 100 bar).

...continued on page 3

⚠ ATTENTION!

The additional ring weight plate for completing the weights of the base plates (14 + 14a) to 10 bar (stamped with "10 bar") is marked with number 1, the other ring weight plates are numbered with 2 to 6 (PD 60) resp. 2 to 10 (PD 100). Always use them only following this order, i.e. start with no. 1, let no. 2 follow, then add no. 3 etc.

The disc weight plates are not numbered.

Special weights for smaller pressure graduations are available upon request. They may be required for example to compensate operation conditions deviating from our standard reference conditions.

Fig. 1 to 4:

- 1 = Measuring system
- 2 = Screw pump with star handle
- 3 = Oil reservoir
- 4 = Electrical motor
- 5 = Mirror (reading device)
- 6 = Case
- 7 = Connection for external admission pressure ("Vordruck")
- 8 = Vent for admission pressure ("Vordruck")
- 9 = Valve for admission pressure ("Vordruck")
- 10 = Shut-off valve for measuring system ("Messsystem")
- 11 = Shut-off valve for pressure gauge connection "Prüfanschluss"
- 12 = Pressure gauge connection "Prüfanschluss"
- 13 = Union nut (SW 27)
- 14 = Base plate (giving the basic weight)
- 14a = Ring weight base plate
- 15 = Union nut
- 16 = Piston
- 17 = Cylinder
- 18 = Change-over valve external admission pressure ("Vordruck" = admission pressure, "Zu" = closed, "Entlüften" = vent)
- 19 = Adjustable feet
- 20 = Leveling bubble
- 21 = Oil drain port "Ölablass" (to drain off the overflow of the system after approx. 40 hours of operation)
- 22 = Switch for electrical motor drive
- 23 = ID plate for official calibration of a gauging office
- 24 = ID plate with model code and serial number of manufacturer

Key Plan

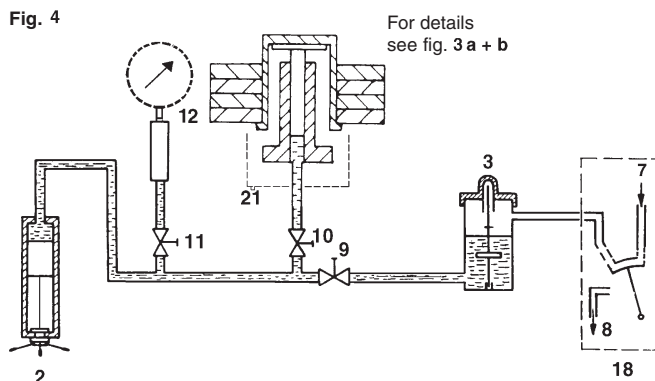

Fig. 1

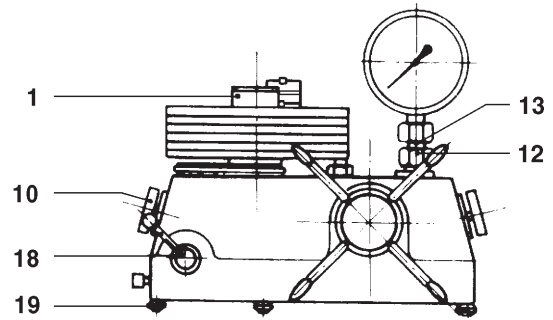

Fig. 2

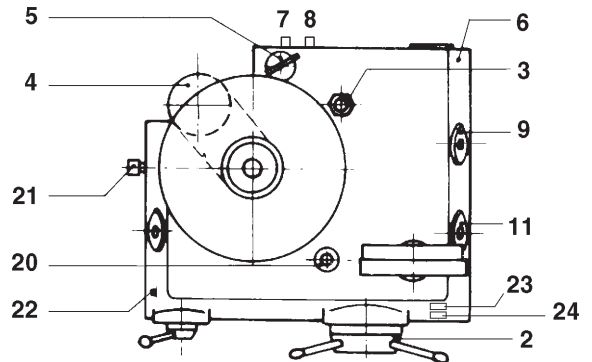

Fig. 3a

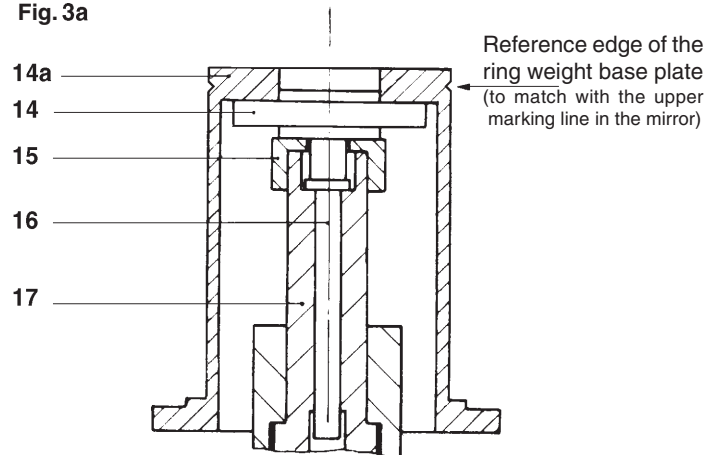
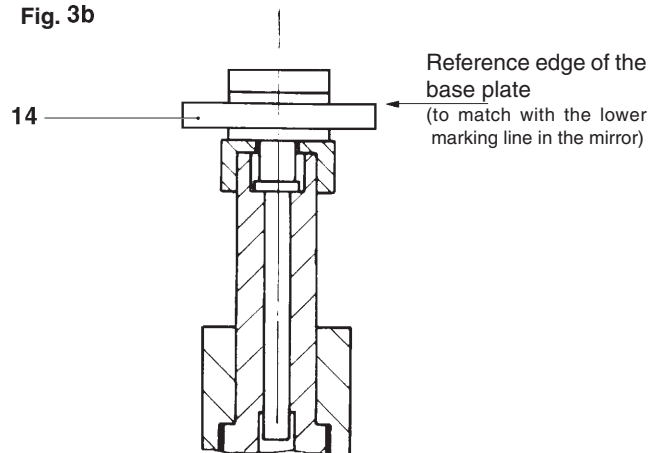

Fig. 3b



The information in this leaflet is given in good faith, but we reserve the right to make changes without notice.