

The overrange protector is a piston valve. The piston will remain in an "open" position as long as the pressure of the medium is lower than the counter pressure activity on the piston due to the spring. As soon as the pressure of the medium becomes higher than the counter pressure caused by the spring, the piston will move towards the spring and the piston valve closes. After the pressure has decreased by approximately 25% below the set closing pressure, the valve opens and the spring force causes the piston to return to its original "open" position.

The overrange protector has been designed to protect pressure gauges against a pressure overload higher than the measuring range. It allows to put several gauges with different pressure ranges in ascending stages and makes it possible to read even low ranges in a precise way, when the total range is in fact much higher. Therefore the overrange protectors will be adjusted correspondingly to each maximum range of the several gauges and then simply turn the gauges off.

Requirement for a constant troublefree operation is a pressure medium free of solid particles. Granular impurities in the medium damage the o-ring seal that is preventing the valve from closing at excess pressure.

The valves are not suitable for use as regulators.

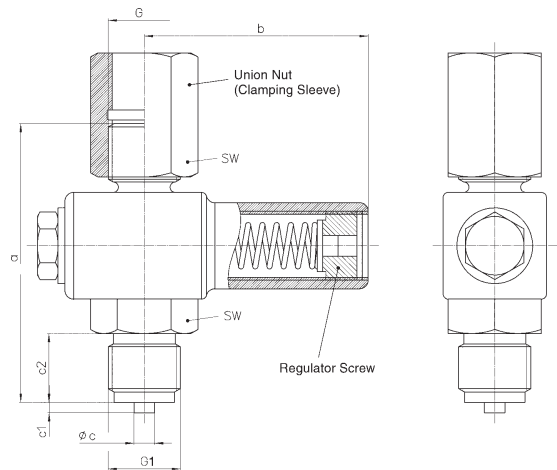

Dimensional Data (mm / inches)

	a ±1	b ±1	c	c1	c2	G	G1	SW
mm	80	65	6	3	20	G ½	G ½ A	27
inch	3.15	2.56	.24	.12	.79	½" BSP-F	½" BSP-M	1.063

Standard Configuration

Brass-Version

- **Valve housing**
Brass
- **Piston**
316 stainless steel (1.4571)
- **Instrument connection**
Union nut carbon steel, ½" BSP female
- **Process connection**
½" BSP male, brass
- **O-ring**
Viton
- **Max. pressure**
600 bar
- **Vacuum resistance**
Full vacuum, but no setting at vacuum possible

Stainless Steel Version

- **Valve housing**
316 stainless steel (1.4571)
- **Piston**
316 stainless steel (1.4571)
- **Instrument connection**
Union nut 316 stainless steel (1.4571), ½" BSP female
- **Process connection**
½" BSP male, 316 stainless steel (1.4571)
- **O-ring**
Viton
- **Max. pressure**
1000 bar (~15,000 psi)
- **Vacuum resistance**
Full vacuum, but no setting at vacuum possible

Model	Adjustment Range in bar	Ordering-Number (for standard configuration only)	
		Brass	316 stainless steel
S 2,5	.4 - 2.5	Z - 04 10 01	04 30 01
S 6	2 - 6	Z - 04 10 02	04 30 02
S 25	5 - 25	Z - 04 10 03	04 30 03
S 60	20 - 60	Z - 04 10 04	04 30 04
S 250	50 - 250	Z - 04 10 05	04 30 05
S 400	240 - 400	Z - 04 10 06	04 30 06

Optional Special Configurations

- Process connection
½" NPT or M 20 x 1,5
- Free of oil and grease for oxygen service
- DVGW-Version

How to Order:

Please specify:

Ordering number: only for standard configuration, see table above

Model code: see table above

Material: brass or stainless steel

Special configuration: see above

Examples for Ordering Information:

- Z-041002 (= S6, brass)
- S25, 316 stainl. steel, process connection ½" NPT

The information in this leaflet is given in good faith, but we reserve the right to make changes without notice.



ARMATURENBAU GmbH

Manometerstraße 5 • D-46487 Wesel - Ginderich
Phone: (0 28 03) 91 30-0 • Fax: (0 28 03) 10 35
armaturenbau.com • mail@armaturenbau.com



Subsidiary Company and Sales East Germany and Eastern Europe

MANOTHERM Beierfeld GmbH 11500

Am Gewerbepark 9 • D-08340 Beierfeld
Phone: (0 37 74) 58 - 0 • Fax: (0 37 74) 58 - 545
manotherm.com • mail@manotherm.com