

Bourdon Tube Pressure Gauges

Case and Bayonet Ring Stainless Steel
Standard (RCh) or Liquid Filled (RChG)

NCS 100 mm (4")
160 mm (6")
250 mm (10")

Accuracy Class 1.0

Models

RCh
RChG

Application

For fluid and gaseous media (compatible to the wetted materials), which are not highly viscous and do not tend to polymerize, especially where a sealed case and/or chemical resistance are required.

Nominal Case Sizes (NCS):

Model RCh: 100, 160, 250 mm (4", 6", 10")

Model RChG: 100, 160 mm (4", 6")

Accuracy Class (EN 837-1)

1.0 (i.e. $\pm 1.0\%$ f.s.)

Pressure Ranges (EN 837-1)

Version – 1*: 0-0.6 to 0-1000 bar, 0-10 to 0-15,000 psi

Version – 2*: 0-1600 bar, 0-20,000 psi

Version – 3*: 0-0.6 to 0-1600 bar, 0-10 to 0-20,000 psi

also corresponding vacuum and compound pressure ranges
(*see below)

Pressure Limitations

Steady pressure: full scale value
Cyclic pressure: 90% of full scale value
Overpressure: 130% of full scale value

Protection Type (EN 60 529 / IEC 529)

Model RCh = IP 54 / Model RChG = IP 65

Further information about advantages, applications, specifications, temperature limitations and pressure ranges of Bourdon tube pressure gauges, accuracy classes 1.0 and 1.6 according to EN, can be found on **general information leaflet 1000**.

Standard Configuration

Process Connection

G ½ B (½" BSP) bottom connection, optionally: lower back (r)

Wetted Parts

Ordering code –1: Socket: brass
Bourdon tube: ≤ 40 bar = bronze, C-form, (≤ 800 psi) soft soldered
 ≥ 60 bar = 316 Ti (1.4571), ($\geq 1,000$ psi) helical, silver brazed

Ordering code –2: Socket²⁾: 316 Ti stainless steel (1.4571)
Bourdon tube: alloy steel, helical, argon arc welded

Ordering code –3: Socket²⁾: 316 Ti stainless steel (1.4571)
Bourdon tube: argon arc welded,
 ≤ 40 bar = 316 Ti (1.4571), (≤ 800 psi) C-form
 ≥ 60 bar = 316 Ti (1.4571), ($\geq 1,000$ psi) helical³⁾,
1600 bar = NiFe-alloy, helical³⁾, (20,000 psi)

Movement

Version –1 = brass/German silver; –2 and –3 = stainless steel

Dial:

Aluminum alloy, black figures, white background

Pointer:

Aluminum black

Case and Ring

304 stainless steel (1.4301), bayonet ring

Window

Version –1: single strength glass, –2 and –3: laminated safety glass

Case Filling

Model RChG only: Glycerine

Safety Features

RCh: 1" Blow-out ($\varnothing 25$ mm) in the back of the case

RChG 100: Blow-out $\varnothing 40$ mm (~ 1.57 ") in the back of the case, with pressure equalizing membrane

RChG 160: Top blow-out device



Special Options

- Wetted parts **monel** = ordering code: – 6: pressure ranges 0-0.6 to 0-600 bar and 0-10 psi to 0-10,000 psi, Bourdon tube argon arc welded, stainless steel movement
- Process connection M 20 x 1.5, ½" NPT, G ¼ B, ¼" NPT, high-pressure connections; others upon request
- Inlet port restrictor screw brass, stainless steel, or monel
- Pressure ranges 0-2500 bar, 0-30,000 psi, 0-35,000 psi, version –2 or –3, pressure limitation at steady pressure: full scale value, at cyclic pressure: 65% of full span, HP-connection with M16x1.5 female and sealing cone for ¼" pipe; optionally with 9/16–18 UNF female or 9/16–18 UNF (left) male; others upon request
- Special scales, such as dual ranges, special units, fine division (with knife edge pointer) etc.
- Refrigerant gauge, see technical info. sheet T01-000-015
- Receiver gauges 0.2-1 bar or 3-15 psi
- Micro-adjustable pointer, mechanism aluminum
- Stationary red pointer on the dial
- Maximum-indicating pointer (pressure ranges $\geq 0-2.5$ bar) or stationary red pointer with external adjustment, acrylic glass resp. polycarbonate lens
- Other than vertical installation; top or side connection
- NCS 100 or 160 (4", 6") for higher temperatures
- Other case fillings, e.g. silicone oil for low temperatures down to -40 °C and others upon request
- Electrical accessories, see data sheets 1291 and 9000 ff

How to Order:

Model code: **RCh** (no case filling, IP 54)
RChG (filled case, IP 65)
RCh(G) (fillable case, IP 65)

Nominal case size: **100, 160, 250**

Wetted parts: **– 1, – 2 or – 3** (see left side)

Case configuration: **r, Rh, rRh, Fr, rFr, rBFr**
(compare overleaf) (standard case = bottom connection = without additional code letter)

Pressure range: according to EN 837-1
e.g. 0 - 4 bar or 0-60 bar

Process connection: **G ½ B** (½" BSP, standard) or **½" NPT**
(others: see above)

Special options: (see above)

Examples for Ordering Information:

- RCh 100–3 rFr, 0-6 bar, G ½ B (or ½" BSP)
- RChG 160–1, -1/+9 bar, ½" NPT



ARMATURENBAU GmbH

Manometerstraße 5 • D-46487 Wesel - Ginderich
Phone: (0 28 03) 9130-0 • Fax: (0 28 03) 10 35
armaturenbau.com • mail@armaturenbau.com



Subsidiary Company and Sales East Germany and Eastern Europe

MANOTHERM Beierfeld GmbH

Am Gewerbepark 9 • D-08344 Grünhain-Beierfeld
Phone: (0 37 74) 58-0 • Fax: (0 37 74) 58-545
manotherm.com • mail@manotherm.com

1201
9/05

Case Configuration, Code Letters, Dimensional Data and Weight

Bottom connection,
without code letter

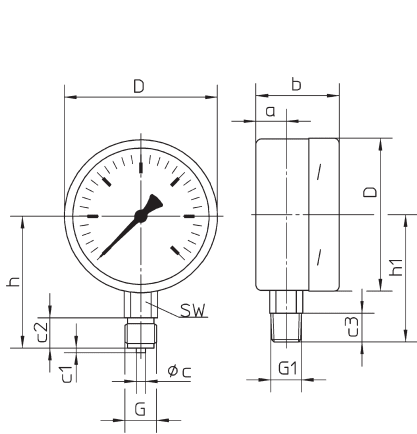

Lower back connection,
code letter: **r**

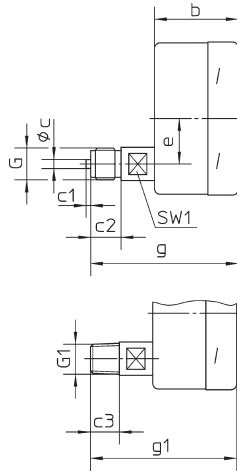

Bottom connection,
rear mounting flange¹⁾,
code letters: **Rh**

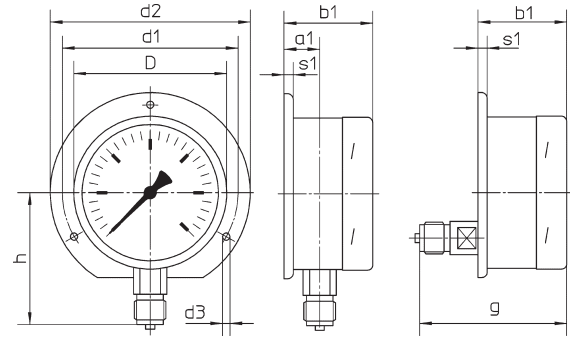

Lower back connection,
rear mounting flange²⁾,
code letters: **rRh**

Bottom connection, front mounting flange²⁾,
code letters: **Fr**

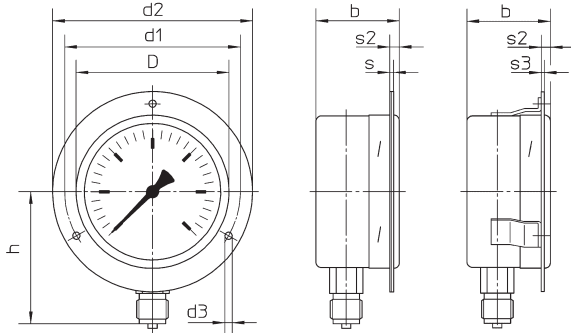

Lower back connection, front mounting flange²⁾,
code letters: **rFr**

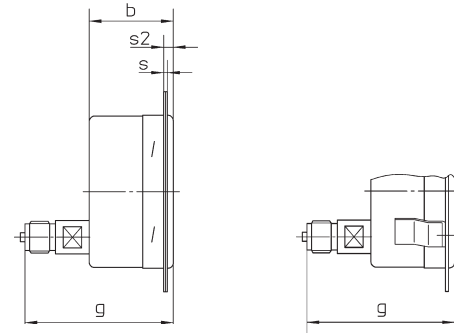

Dry case version, model RCh:
Front flange with longholes attached to the case, and a separate cover front flange

Filled case version, model RChG:
Mounting brackets welded to the case, and a separate front flange

Dry case version, model RCh:
Front flange with longholes attached to the case and a separate cover front flange

Filled case version, model RChG:
Mounting brackets welded to the case, and a separate front flange

Model RCh 160 (dry version) only:
Lower back connection,
U-clamp for panel mounting,
code letters: **rBFr**

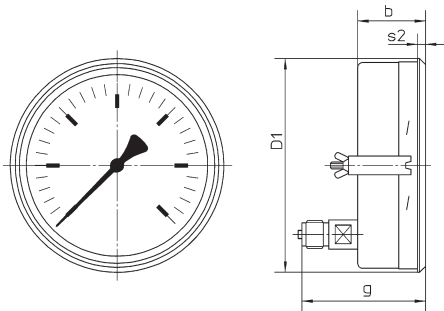

Nominal size 100 according data sheet 1202 only:
Lower back connection,
U-clamp for panel mounting, crimped-on ring,
Model: **RChg** resp. **RChgG 100... rBFr**
(not available with laminated safety glass)

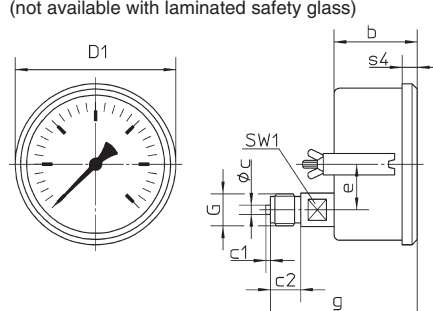

Safety blow-outs:

Model RChG 160:
Top blow-out device

Models RCh 100, 160, 250:
Blow-out Ø 1" (25,4 mm)

Model RChG 100:
Blow-out Ø 40 mm (~1.57")

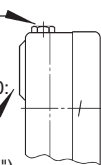

Dimensional Data (mm / inches) and Weight (kg / lb)

NCS	a	a1	b	b1	c	c1	c2	c3	D	D1	d1	d2	d3	e	g	g1
100 4"	20 .79	23.5 .93	55 2.17	58.5 2.30					101 3.98	106 4.17	116 4.57	132 5.20	4.8 .19	30 1.18	97 3.82	96 3.78
160 6"	15.5 .61	19 .75	51 2.01	54 2.13	6 .24	3 .12	20 .79	19 .75	161 6.34	167 6.57	178 7.08	196 7.72	5.8 .23	52 2.05	92.5 3.64	91.5 3.60
250 10"		17.5 .69	58 2.28	60 2.36					251 9.88	—	270 10.63	285 11.22			97 3.82	96 3.78

NCS	G	G1	h	h1	s	s1	s2	s3	s4	SW	SW1
100 4"			87 3.43	84 3.31					10 .39		
160 6"	G ½ B ³⁾ ½" BPS	½" NPT	115 4.53	114 4.49	.08	.24	.24	.04	—	22 .87	17 .67
250 10"			165 6.50	164 6.46	—	.08	—	—	—		

Weight (approx)	
RCh	RChG
.60	.95
1.30	2.10
1.10	1.95
2.40	4.30
2.10	—
4.60	—

¹⁾ RCh 250 with mtg. brackets welded to the case ²⁾ not with nom. size 250 ³⁾ optional M 20 x 1,5

The information in this leaflet is given in good faith, but we reserve the right to make changes without notice.