

Bourdon Tube Pressure Gauges

Case and Bayonet Ring Stainless Steel, American Type (Wide Ring)
with Reed-Switch 201



Model
RCha 63

This data sheet contains all important information about our pressure gauge model RCha 63, provided **with reed contact assembly**.

The reed-switch 201 is a fast making or breaking special switch that is operated with a permanent magnet. It can be used for switching low voltages in the mV or mA range, but also for relatively high switching currents. The way it is designed, the pointer can still move forward on the scale without a change in the switching function.

Technical details and options of model RCha 63 in standard version can be found on data sheet 1210 and general information leaflet 1010. These data are also valid for the reed-switch version, as far as there are no deviating information below. But reed-switch gauges are only available without case filling.

Most special configurations as described on data sheet 1210 are also available for gauges with reed-switches, particularities upon request.

Nominal Case Size

63 (2 1/2")

Safety Features

Standard version with bottom connection with 1" blow-out in the backside of the case; for all the other case configurations available with reed-switch (r, rm, Rh, rRh, rmRh, rFr, rBFR): top blow-out assembly

Minimum Pressure Ranges

Every pressure gauge needs a sufficient amount of torque to operate a limit-switch contact with minimized error. For model RCha 63 with reed-switch a minimum range of 2.5 bar or 30 psi (also compound ranges) has to be considered.

Adjustment

The reed switch can be adjusted to any pressure value between minimum 2% and maximum 90% of full scale value. (Take off bayonet ring for adjustment.)

A removable key for adjusting the set point from outside (through the window; window: perspex glass) is optionally available.

Make / Break Operations

Switching is requested when the pointer is moving in clockwise direction (e.g. rising pressure or decreasing vacuum; standard-version):

R1 making or **R2 breaking**

Switching is requested when the pointer is moving counterclockwise (e.g. decreasing pressure or rising vacuum):

R4 making or **R5 breaking**

Building in 2 reed-switches is possible in any combination of above mentioned switching functions.

The minimum distance between the 2 set points is 25% of the full scale value.

To guarantee an accurate switching function it is very important to order the required **switching direction properly**, because the switching hysteresis has to be considered.

Characteristically for a reed-switch is the fact that after a switching contact took place, the pointer can still move forward on the scale without a change in the switching function.



Electrical Connection

1 m (39,4") connection cable, 2 wires, cable lead-through at the bottom of the right side of the case (right side from a viewer's perspective), versions r, rm, rFr and rBFR with cable lead-through at the backside; other positions upon request (extra charges!); Terminal box, plug connector DIN EN 175 301-803, screwed cable gland M12x1.5 or PG9 upon request

Electrical Data

Max. switching capacity	10 W (DC) or 10 V (AC)
Max. switching voltage	< 75 V DC < 50 V AC
Max. switching current	.5 A DC or AC with resistive load
Switching hysteresis	max. 2.5 %

CE-marking

According EMC Directive, restricted to max. 5 switchings/minute

Temperature Limitation

For the reed-switch: -30 °C (-22 °F) up to + 75 °C (167 °F)

For the temperature limitations of the pressure gauges please compare data sheet 1210 and general information leaflet 1010.

Safety Instruction

Instruments with reed-switch may not be applied close to any strong magnetic fields (e.g. resistance welders).

How to Order:

Please specify the pressure gauge model as described in data sheet 1210. The ordering code for the pressure gauge model is extended by the

- Code letter for the reed contact and the
- Code number for the make/break operation (see left)

e.g.: **R1 making** at clockwise pointer move
R2 breaking at clockwise pointer move
R4 making at counterclockwise pointer move
R5 breaking at counterclockwise pointer move

Special options: upon request

Examples for Ordering Information:

- RCha 63-1, 4 bar, 1/4" BSP (resp. G1/4B), R1
- RCha 63-1, rFr, 6 bar, 1/4" NPT, R21
- RCha 63-3, rFr, 25 bar, 1/4" NPT, R24



ARMATURENBAU GmbH

Manometerstraße • D-46487 Wesel - Ginderich
Phone: (0 28 03) 91 30-0 • Fax: (0 28 03) 10 35
armaturenbau.com • mail@armaturenbau.com



Subsidiary Company and Sales East Germany and Eastern Europe

MANOTHERM Beierfeld GmbH

Am Gewerbehark 9 • D-08340 Beierfeld
Phone: (0 37 74) 58 - 0 • Fax: (0 37 74) 58 - 545
manotherm.com • mail@manotherm.com

1219.4

6/02

Case Configurations, Code Letters, Dimensional Drawings and Weights

Please compare data sheet 1210. The front-to-back sizes are different than the dimensions of the basic model.

The position of the cable entry is shown in the dimensional drawings below. Other positions for the cable entry only upon request (extra charges!).

Bottom connection, without code letters

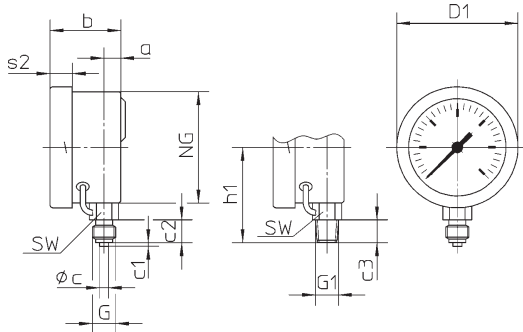

Lower back connection, code letter: **r**

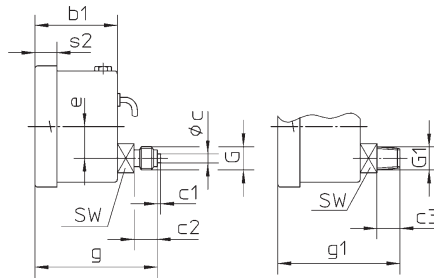

Center back connection, code letters: **rm**

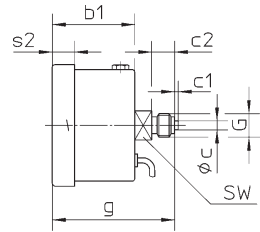

Bottom connection, rear mounting flange, code letters: **Rh**

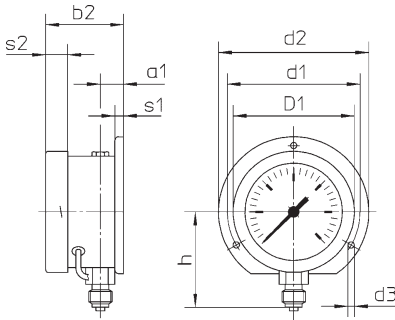

Lower back connection, rear mounting flange, code letters: **rRh**

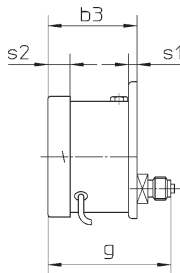

Center back connection, rear mounting flange, code letters: **rmRh**

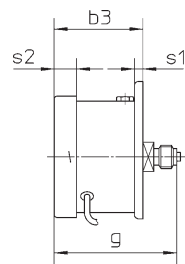

Lower back connection, front mounting flange, code letters: **rFr**

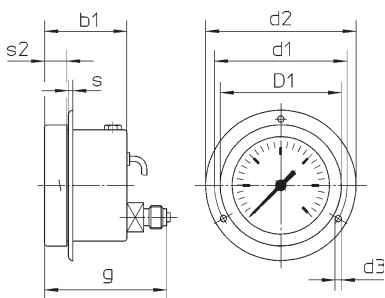

Lower back connection, U-clamp for panel mounting, code letters: **rBFr**

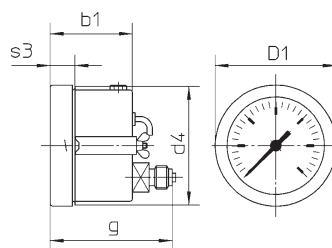

Dimensions (mm / inches) and Weight (kg / lb)

Nom. Size	D1	a	a1	b	b1	b2	b3	c	c1	c2	c3	d1	d2	d3	d4	e	G	G1	g	g1
63 2½"	68.5 2.70	9.5 .37	13 .51	40 1.57	46.5 1.83	44 1.73	50 1.97	5 .20	2 .08	13 .51	13 .51	75 2.95	85 3.35	3.6 .14	67 2.64	18 .71	G ¼ B ²⁾ ¼" BSP	¼" NPT	69 2.72	69 2.72

Nom. Size	h±1	h1±1	s	s1	s2	s3	SW	Weight ¹⁾ (approx.)
63 2½"	54 2.13	54 2.13	2.5 .10	5 .20	12,5 .49	14 .55	14 .55	.250 kg .55 lb.

¹⁾ approx. weight for standard version with bottom connection; others upon request

²⁾ optional M 12 x 1.5

The information in this leaflet is given in good faith, but we reserve the right to make changes without notice.