

Combi Gauges for Rail Cars

According to DIN 38 030:2008

With one Measuring Unit

Models **Rg...Fz**
RChg...Fz

Application

Pressure gauges **NCS 60** Model **Rg** **60-1 Fz rmBFR**,
NCS 80 Model **RChg** **80-1 Fz rmBFR**,
NSC 100 Model **RChg** **100-1 Fz rmBFR**,

are applied for rail cars, especially for pneumatic brake systems and are in accordance with the norm DIN 38 030:2008.

The instruments are provided with u-clamps for panel mounting and they combine direct and indirect lighting.

Standard Version according to DIN 38 030:2008

Accuracy

Class 1.6: NCS 60 (2.36")

Class 1.0: NCS 80, 100 (3", 4")

Position of Installation

70° – 90° (position of adjustment 80°)

Case

NCS 60 (2.36") steel, galvanised
NCS 80, 100 (3", 4") 1.4301 (304 stainless steel)
with crimped-on ring, aluminum, black anodised

Case Protection Type (EN 60529 / IEC 529)

IP 54 in front of the panel

Blow-out Device

Blow-out plug no. 19 in the back of the case

Lighting

Directly 1 x BA9s 24 VDC / 2 W and indirectly by lighting apertures in the case

Nominal Case Sizes

60, 80, 100 mm (2.36", 3", 4")

Wetted Parts

Connection: brass
Bourdon tube: bronze, soft soldered, c-form

Case Configuration

Position of the connection: centre back connection (rm)
Mounting device: u-clamp for panel mounting (BFR)

Pressure Ranges

0-6, 0-10 and 0-12 bar

Process Connection

NCS 60 (2.36"): M 12 x 1.5 including chuck cone for cutting ring
L 6 according to DIN EN ISO 8434-1
NCS 80, 100 (3", 4"): M 16 x 1.5 including chuck cone for cutting ring
L 10 according to DIN EN ISO 8434-1

Including restrictor screw in the pressure inlet port, orifice Ø 0.8 mm (0.03")

Window

Reflex-reduced laminated safety glass

Movement

Brass / German Silver

Dial

Aluminum black, white scale, with zero stop (stop pin)

Pointer

Aluminum, colour yellow (RAL 1016)



Safety Category according to EN 837-1

S1 pressure gauges with blow-out device

Options and others

- Instruments without combination of lighting, meaning either direct or indirect lighting
- Other pressure ranges, e.g. 0-16 bar
- Other than 70° - 90° installation
- Process connection with cutting ring and union nut
- Other process connections upon request
- Restrictor screw brass, orifice Ø 1.0 mm (0.04"), in the inlet port
- Selectable colours for pointer, e.g. red (RAL 3026) or white (RAL 9010)
- Dial inscription (ZA) according to your demand, in terms of colour matching the pointer
- Coloured marks matching the pointer
- LED lighting for operating voltages of more than 32 V AC/DC up to max. 130 V for NCS 80 and 100
- BA9 LED light 24-32 V AC/DC
- Direct lighting with BA7s (24 VDC / 3 W) upon request

Ordering Information:

Model: **Rg 60-1 Fz rmBFR**
RChg 80-1 Fz rmBFR
RChg 100-1 Fz rmBFR

Pressure range: **0- 6 bar, 0-10 bar, 0-12 bar**

Process connection: **L 6 (NCS 60)**
L 10 (NCS 80, 100)

Specifics: e. g. dial inscriptions (**ZA**),
other position of installation etc.
(see above)

Example:

- RChg 80-1 Fz rmBFR, 0-12 bar, L 10
ZA: "brake cylinder" white



ARMATURENBAU GmbH
Manometerstraße 5 • D-46487 Wesel - Ginderich
Tel.: +49 (0) 28 03 / 91 30-0 • Fax: +49 (0) 28 03 / 10 35
armaturenbau.com • mail@armaturenbau.com



Subsidiary Company, Sales and Export East

MANOTHERMBeierfeld GmbH
Am Gewerbepark 9 • D-08344 Grünhain-Beierfeld
Tel.: +49 (0) 37 74 / 58-0 • Fax: +49 (0) 37 74 / 58-545
manotherm.com • mail@manotherm.com

1901
9/08

Case Configuration, Dimensions and Weight

Rg 60-1 Fz rmBFr

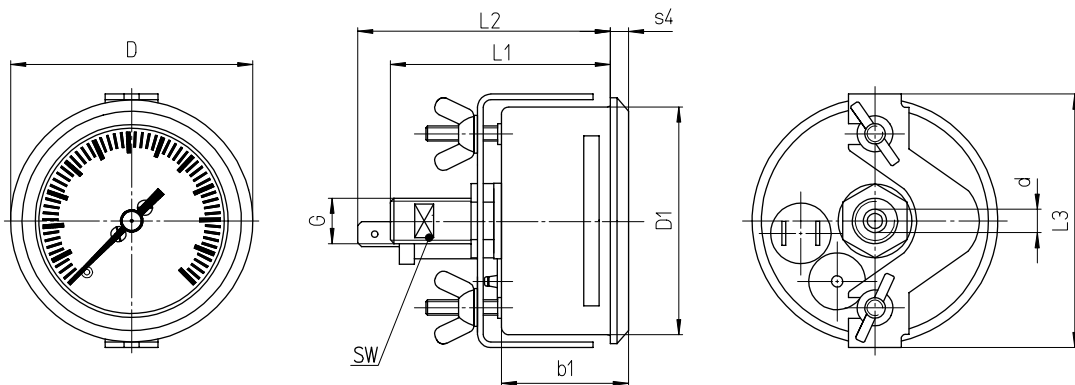

RChg 80-1 Fz rmBFr

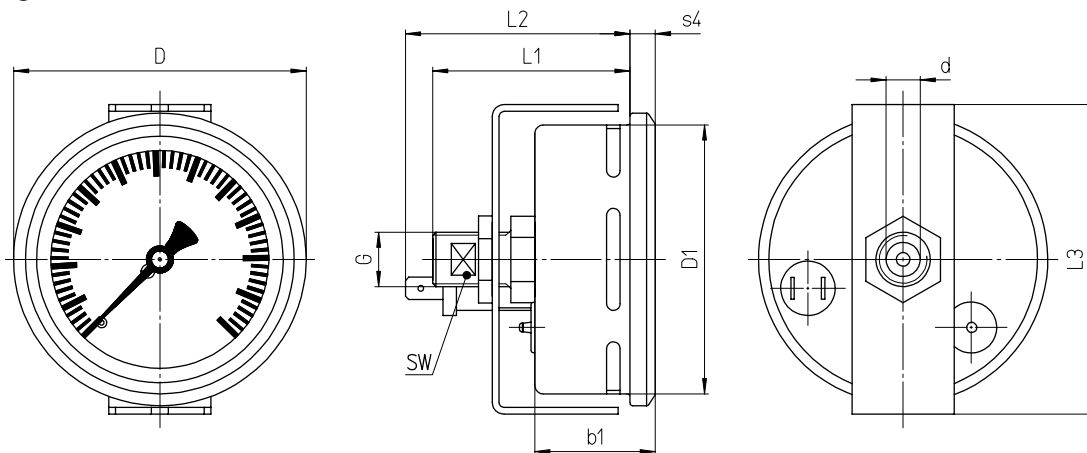

RChg 100-1 Fz rmBFr

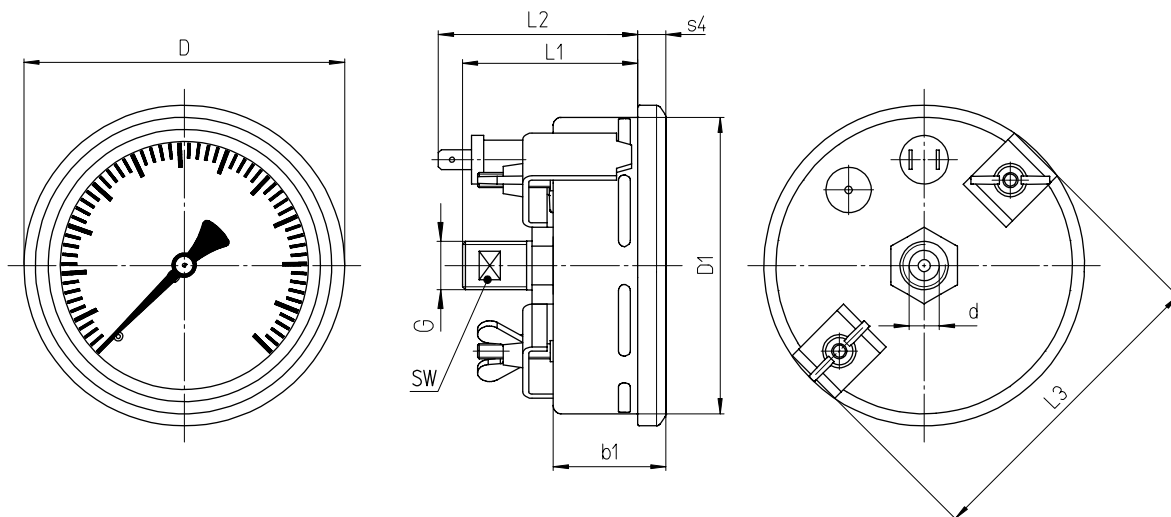

Dimensional data (mm / inches) and weights (kg / lb)

NCS	b1	D	D1	Process connection EN ISO 8434-1		L1	L2	L3	s4	SW	recommended panel cut out Ø	Weight (approx.)
				d ^{B11 1)}	G							
60	33	65	59	L6	M 12 x 1.5	59	67	67	5	8	61 ± 0.5	0.20
2.36	1.3	2.56	2.32	.24		.24	2.32	2.64	2.64	.2	.31	2.4 ± 0.02
80	35.5	86	79	L10	M 16 x 1.5	58	66	91	7.5	13	81 ± 0.5	0.35
3	1.4	3.39	3.1			.39	.39	2.28	2.6		3.58	.3
100	37	106	99	.39		57	65	101	10	.51	102 ± 1	0.39
4	1.46	4.17	3.89			.39	.39	2.24	2.56		3.98	.39

¹⁾Tolerance class according to ISO 286-2

The information in this leaflet is given in good faith, but we reserve the right to make changes without notice.